

ARJO

RHAPSODY/PRIMO P200+ Operating and Product Care Instructions



04.AR.09/9GB
December 2006



CE

© ARJO Hospital Equipment AB 2006

ARJO products are patented or patent pending. Patent information is available by contacting ARJO Hospital Equipment AB.

Our policy is one of continuous development, and we therefore reserve the right to make technical alterations without notice. The content of this publication may not be copied either whole or in part without the consent of ARJO Hospital Equipment AB.

Contents

Foreword	5
Safety instructions	6
Intended use	6
Labels	8
Parts designations	10
Control Panel	13
Basic functions	14
Foot rest	14
Pillow	14
Shampoo and Bath Oil	14
Autofill function (optional)	14
Emergency lowering (optional)	14
Preparations for bath	16
Hydromassage	18
Hydrosound	22
Disinfection/cleaning instructions	24
Stillbath and Hydrosound	26
Hydromassage	28
Stainless Steel	30
General information/cleaning	31
Care and maintenance	32
Preventive Maintenance Schedule -Rhapsody/ Primo P200	32
Technical specifications	35
Electric supply	35
Water supply	35
Safe Working Load	35
Accessories	36

Foreword

Thank you for purchasing ARJO Equipment

Your ARJO Bath System is part of a world-wide family of quality products designed especially for efficient resident hygiene and good ergonomics for the care-giver.

We are dedicated to serving your needs and providing the best products available along with training that will bring your staff maximum benefit from every ARJO product.

Please contact us if you have any questions about the operation or maintenance of your ARJO Bath System.

Please read this manual thoroughly!

Please read this manual in its entirety before using your Bath System. Information in the manual is crucial to the proper operation and maintenance of the equipment, and will help protect your product and ensure that the equipment performs to your satisfaction. Some of the information in this manual is important for your safety and must be read and understood to help prevent possible injury.

ARJO strongly advises and warns that only ARJO designed parts, which are designed for the purpose, should be used on equipment and other appliances supplied by ARJO, to avoid injuries attributable to the use of inadequate or incompatible parts.

Unauthorised modifications on any ARJO equipment may affect its safety. ARJO will not be held responsible for any accidents, incidents or lack of performance that occur as a result of any unauthorised modification to its products.

Service and Support

A service routine must be done on your Bath Systems every year by ARJO authorised service personnel to ensure the safety and operating procedures of your product.

See chapter Preventive Maintenance Schedule.

If you require further information, please contact your local ARJO representative who can offer comprehensive support and service programs to maximise the long-term safety, reliability and value of the product.

Contact your local ARJO representative for replacement parts. Your service representative stocks the parts you will need. The telephone number appears on the last page of this manual.

Study the video for your Bath System

An instruction video accompanies this manual.

Please note that the video does not replace the information in this manual as the latter also contains important safety instructions.

For the UK market this manual is accompanied by a separate document regarding Thermostatic Mixer FMM 5193.

Symbols definition in this manual:



WARNING!

Means:

Safety warning. Failure to understand and obey this warning may result in injury to you or to others.

NOTE!

Means:

This is important information for the correct use of this system or equipment.

CAUTION

Means:

Failure to follow these instructions may cause damage to all or parts of the system.

Safety instructions

This equipment must be used in accordance with these safety instructions.

Anyone using this equipment must also have read and understood the instructions in this manual.

If modifications are made to the equipment without the expressed acknowledgement of ARJO, or if the product is not checked and maintained according to the chapter on Care and Maintenance in this manual, the liability of the product will be invalidated.

Intended use

This equipment is intended for therapeutic bathing and showering hospital or care facility residents under the supervision of trained skilled nursing staff in accordance with the instructions outlined in the Operating and Product Care Instructions. All other uses must be avoided.

Equipment fitted with a bath tub disinfection device must be disinfected according to the instructions established in the Operating and Product Care Instructions. All other uses of the disinfection device must be avoided.

The equipment must only be used for the purposes stated above, and must be installed according to the Assembly and Installation Instructions, which can only be superseded by local code.

The normal useful life of this equipment, unless otherwise stated, is ten (10) years, subject to required preventative maintenance as specified in the Operating and Product Care Instructions, the Assembly and Installation Instructions and the Spare Parts catalogue.

Always make sure that:

- the equipment is handled by trained staff.
- the water/shower temperature is checked by hand before the bath.

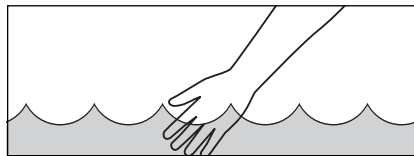

- equipment is properly disinfected after each bath.
- the lift with the resident is out of the bath's working area if the tub is raised to enable quicker draining.
- your skin and eyes are protected against concentrated disinfectant/cleaner. Carefully follow the instructions on the disinfectant/cleaner bottle!

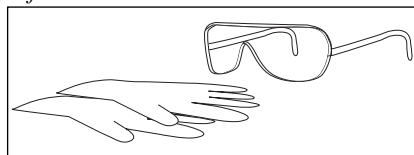

- all lifting/transporting equipment is in good condition, follow the instructions for all equipment.
- there are no sharp edges on parts coming in contact with residents.
- stretchers, chair seats, mattresses etc., are fastened and all screws tightened. Also check for cracks and tears that would allow water to get into the mattress filling. If there is such damage, replace!
- the wheels of lifts are locked during transfers and when the lift is inside the tub.
- the resident is sitting firmly and securely fastened, to avoid injuries.
- lifts are moved with care, especially in narrow passages, over bumps etc.
- the resident's hands and feet are placed on appropriate rests.
- all safety straps are in good condition and properly fastened.
- the equipment is not switched off via the safety switch. The safety switch is for emergency situations and service only.



WARNING:

When lowering the bath tub the operator must ensure that there are no obstructions in the immediate vicinity that could impede its downward movement.

Failure to remove obstructions could result in severe injury to operator/resident and damage the tub.

When raising the bath, ensure that no part of the resident lift chair or stretcher is in contact with the bottom or rim of the tub.

Do not allow the resident or operator to sit on the end or side of the bath tub.



WARNING:

A professional assessment of residents must be carried out to ensure their suitability for use with this product.



WARNING:

Equipment not suitable for use in presence of flammable anaesthetic gases.

NOTE!

Modifications made to the equipment without express acknowledgement from ARJO will invalidate supplier's product liability.

Labels

Data label

On the data label you will find the following information:

- Voltage and AC frequency
230/240 V ~ 50 Hz (EU-models)
- Power maximum 1100 VA
- Protection code IPX4 (IEC 529), i.e. the product is protected against splashing water.



Type B
Applied part: protection against electrical shock in accordance with IEC 60601-1.

- Class I equipment.
- Mode of operation for Hi/Lo function:
Max 2min ON and 18 min OFF

Mode of operation for Hydrosound/Hydro-massage function:
Max 15min ON and 15min OFF
- SWL-Safe Working Load
(Maximum lifting capacity)
500 kg (1100 lb.)



Lifting stroke 500mm (19 5/8")



Read the operation manual before use.



Separate electrical and electronic components for recycling in accordance with the European Directive 2002/96/EG (WEEE)

Attention label

Attention label placed on the disinfectant spray handle and means:

See the accompanying documents.

Water connection label

Required max. and min. temperature for cold and hot water and max./min. water pressure.

Identification label

The identification label states the product number and the serial number.

CE marking (EU-models 230/240V - 50 Hz)

The product is CE marked according to the Medical Devices Directive 93/42/EEC which also means that the requirements for Electric Safety according to EN 60601-1 and EMC according to EN 60601-1-2 are met.

Approval label

- WRAS approved to the UK Water Supply Bylaws
- WRc approval to:
National Health Service
Model Engineering Specification D 08
Thermostatic Mixing Valves
(Healthcare Premises).
Designation Code:
HP- S / HP-T44.



Attention label placed on the disinfectant spray handle

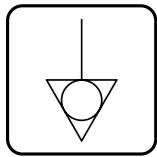
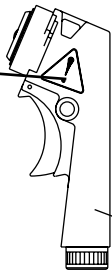

Bonding lug

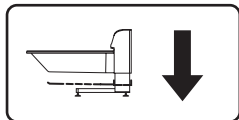

Emergency lowering label

- 230/240V~50 Hz
- MAX 1100 VA
- IPX4
- TYPE 
- Class 1
- ED MAX
- Hi-LO System:
2 min ON/ 18 min OFF
- Hydromassage and Hydrosound:
15 min ON/ 15 min OFF
- Safe Working Load: 500 kg (1100 lb)

 500 mm (19 5/8")

Read the operating instructions before use
Merci de prendre connaissance de la notice d'utilisation
Lesen Sie bitte die Bedienungsanleitung durch

ARJO Hospital Equipment AB Sweden

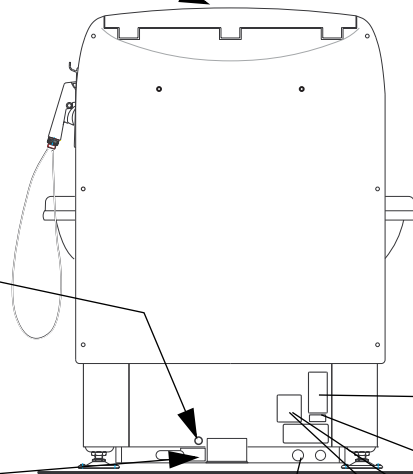

Example of Data label

Address label

Approval label

CE marking

Manufacturing country Manufacturing Year Week
 SE=Sweden E=Eslöv

Serial number

SEE0102001

Product no
AR31211-EU





Serial no
SEE0102001



Made by Arjo in Eslöv, Sweden
010115

Example of identification label

COLD FROIDE KALT MAX 25°C (77°F)	HOT CHAUDE WARM MIN 38°C (100°F) MAX 80°C (175°F)
 MIN 200 kPa (29 psi) MAX 600 kPa (87 psi)	 <small>8418319</small>

Example of Water connection label

Parts designations

- 1 *Emergency lowering handle, optional*
 - 2 *Drain*
 - 3 *Drainage plug*
 - 4 *Surface overflow outlet and drain manoeuvring knob*
 - 5 *Flow meter*
 - 6 *Disinfectant spray handle*
 - 7 *Storage container area (Disinfectant cleaner)*
 - 8 *Control panel*
 - 9 *Lid*
 - 10 *Resident shower handle*
 - 11 *Shampoo dispenser*
 - 12 *Dispenser for Bath oil or if Hydrosound: ArjoSound*
 - 13 *Outlet for tub filling*
 - 14 *Footrest, adjustable*
 - 15 *Pillow*
 - 16 *Tub Rhapsody or optional Primo*
 - 17 *Drainage hose*
 - 18 *Legs*
 - 19 *Foot pads (for 1900 mm tubs)*
 - 20 *Foot (for 1600 mm and 2150 mm tubs)*
 - 21 *Sensor*
- Hydromassage**
- 22 *Filter*
 - 23 *Treatment hose with nozzle*
 - 24 *Hydromassage outlet*
 - 25 *Water flow and Air mix control*
- Hydrosound**
- 26 *Hydrosound Transducing Plate*

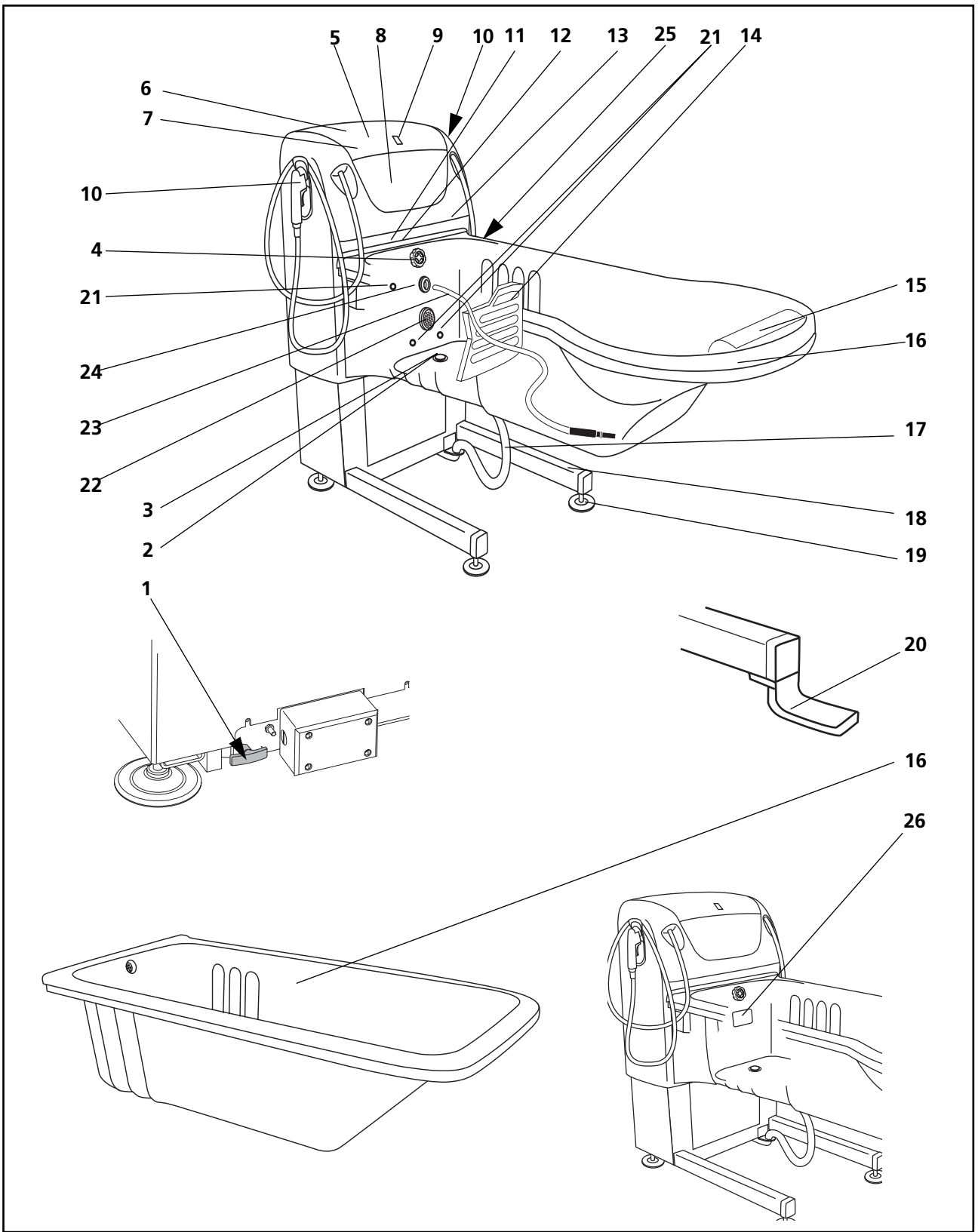

Control Panel

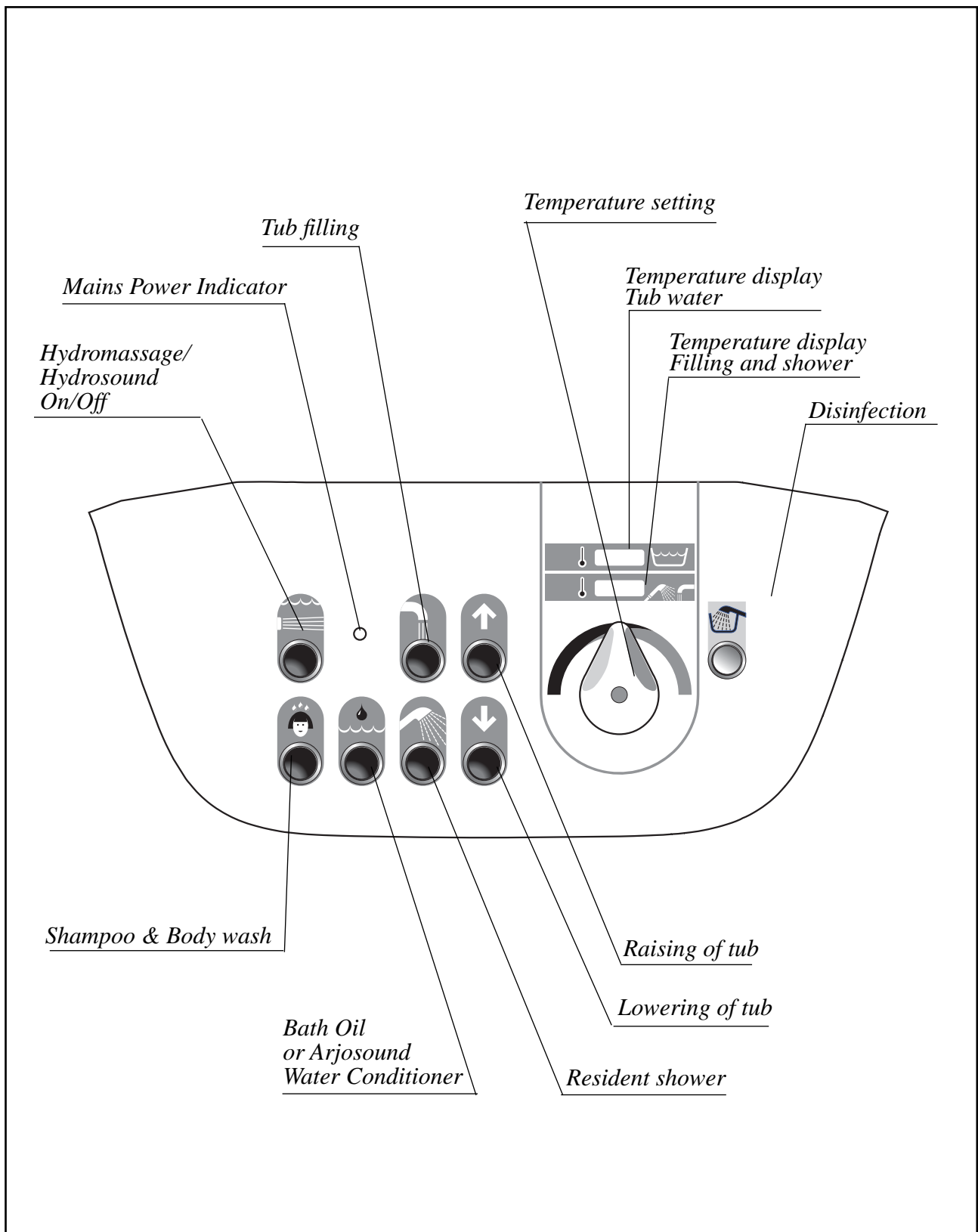

Basic functions

Foot rest

The foot rest (1) is adjustable and can be placed in different positions, depending on the residents length. To place the foot rest in the right position: (see figure 1).

CAUTION

When using Miranti (lift bath trolley), the foot rest must be removed.

Pillow

The pillow (2) is adjustable and attached to the bath tub with the suction cups on the backside of the pillow. Wet the suction cups to improve grip. Place the pillow as convenient and supportive to the resident as possible, (see figure 2). After cleaning the pillow: Let the pillow dry with the suction cups upwards at the bottom of the bath tub.

CAUTION

When using Miranti (lift bath trolley), the pillow should be removed.

Shampoo and Bath Oil

- 1 The bath oil and shampoo bottles are placed under the panel lid (3a). The bottles should be mounted, sufficiently filled and connected to their correspondent hoses and bottle connections (3b).
- 2 Bath Oil and Shampoo is dispensed by pressing correspondent push button on the control panel. Hold your hand under the shampoo outlet when shampoo is dispensed (3c).

When your bath system is equipped with Hydrosound, the Bath Oil is replaced with ArjoSound.

Autofill function (optional)

The bath system is equipped with an autofill function, which is preset on one water level. For adjustments call your Arjo Service Department for assistance.

Emergency lowering (optional)

In case of power failure and the tub needs to be lowered:

Pull the handle on the rear side of the panel (4).

As long as the handle is pulled, the tub will move down.

NOTE!

If a buzzing sound is heard, contact your local ARJO representative for support.

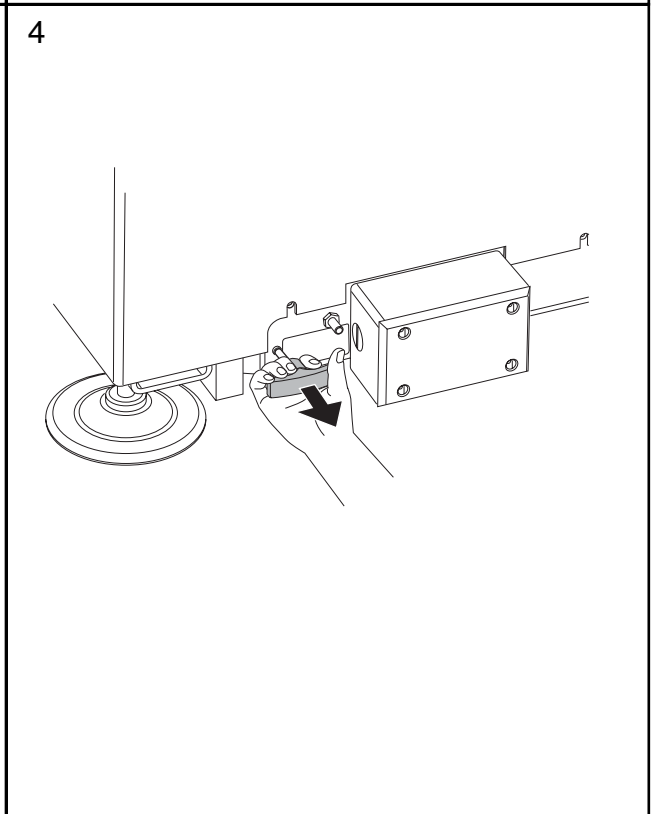
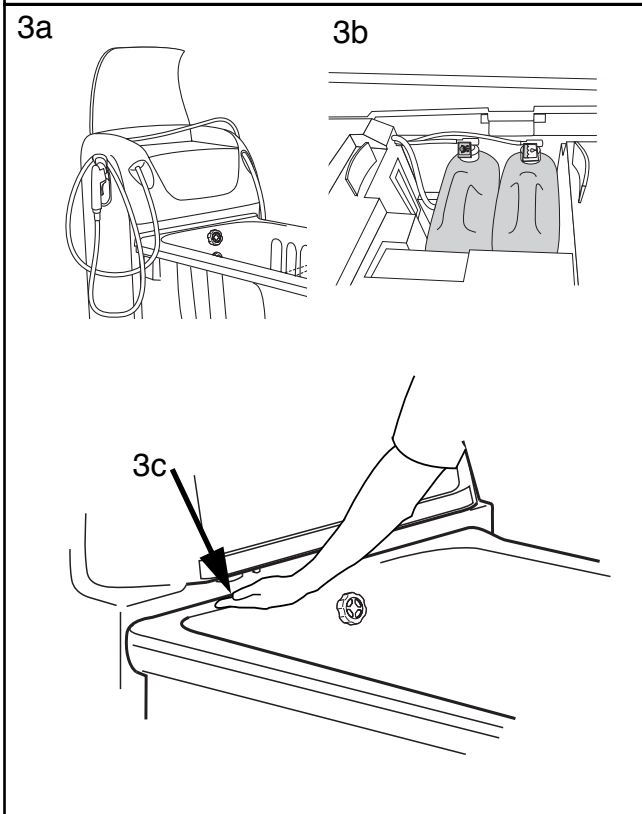
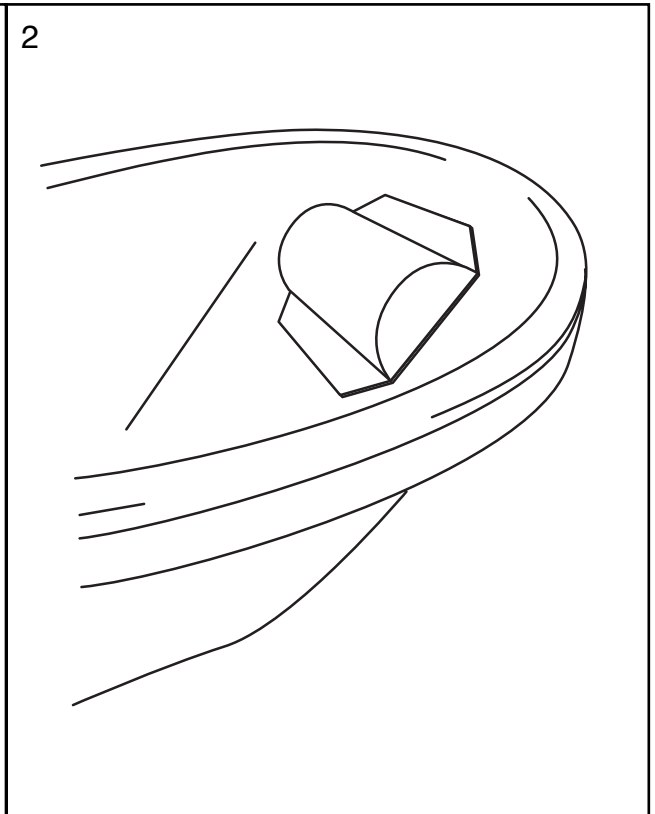
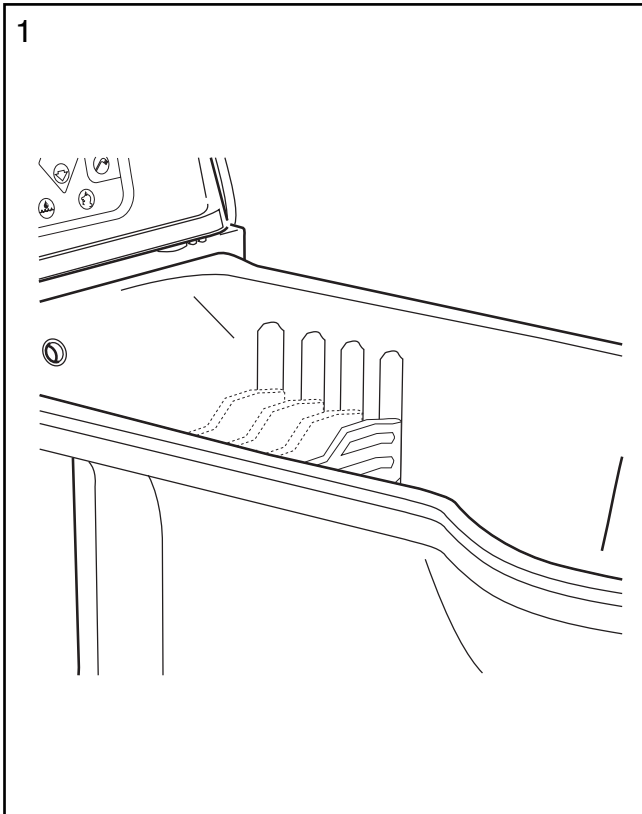

Resident shower

There is either a resident shower on one side of the panel or one on each side. Direct the water stream away from the resident.

- 1 Lift off the shower handle, hold it over the bath and press the trigger handle.
- 2 Press the resident shower button on the control panel. Make sure that there is water flow in the hose for positive drain leakage, by listening. The resident shower can not be activated during tub filling.
- 3 Allow a few seconds for the water to reach the desired temperature.
Check the temperature on the display.
If desired adjust the water temperature by means of the knob on the panel.
- 4 Also check by placing your hand in the water stream that the water temperature feels correct and allow the resident to feel the water with their hand before the water stream is directed on to the resident.

Preparations for bath

The bath is prepared as follows:

- 1 a) Press the tub filling button to fill the tub with water. When the desired level is reached, press the button to stop filling. The display shows the filling temperature. Also check by hand.
- 1 b) Optional, autofill function:
Press the tub filling button to fill the tub with water. (The level is preset). Additional filling is achieved, by pressing the tub filling button continuously. The display shows the filling temperature. Also check by hand.
- 2 Close the drainage plug, attach the foot rest and the pillow.
- 3 Assist the patient into the bath, following the instructions in *Resident handling* (a separate manual).

2

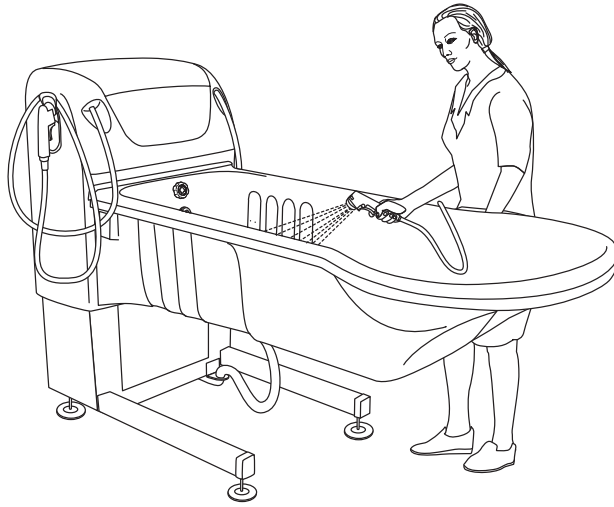

4

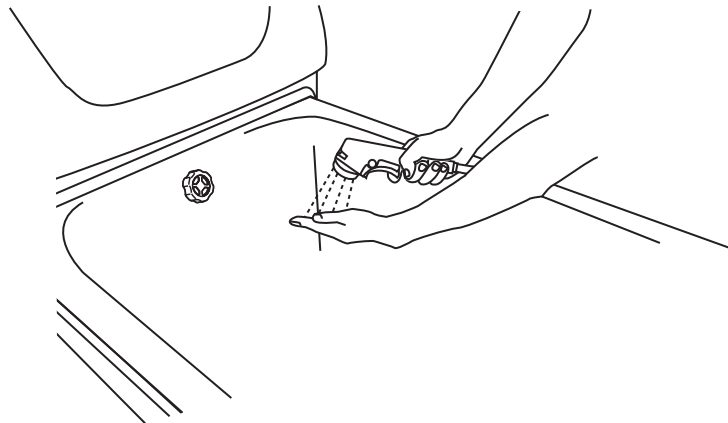

1

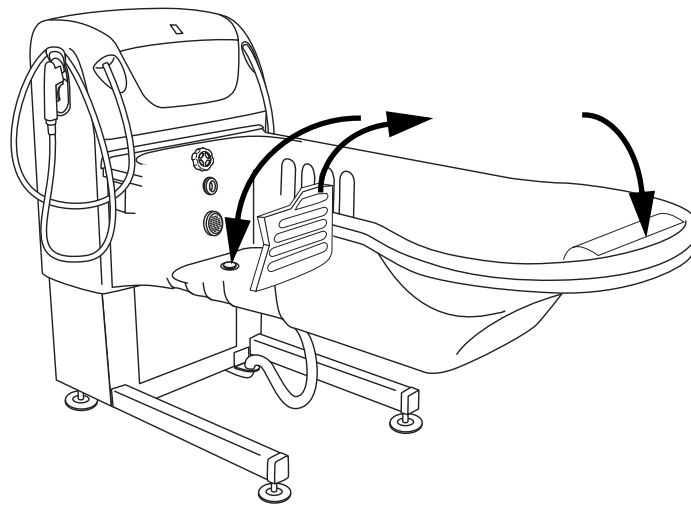

Hydromassage



WARNING!

Do not place the residents head below the water surface.

- 1 Before the hydromassage starts, the tub should be filled with water at the desired temperature, over the hydromassage outlet (A).
- 2 Hydromassage from the built-in jet starts when the hydromassage button on the control panel is pressed.
- 3 After 15 minutes the treatment is automatically ended. During these 15 minutes, the treatment can be stopped by pressing the hydromassage button.
- 4 The water flow is adjusted with the knob on the side of the bath tub. The intensity of the water flow is increased by turning the knob clockwise. *See picture.*
- 5 Adjust the direction of the water-jet by turning the hydromassage outlet.
Remove the adjustable hydro- massage nozzle if you want the jet to cover a wider area. (Just pull it out).
- 6 Raise the resident out of the water, and then rinse the resident thoroughly with the shower to remove soap residue from the skin.

1

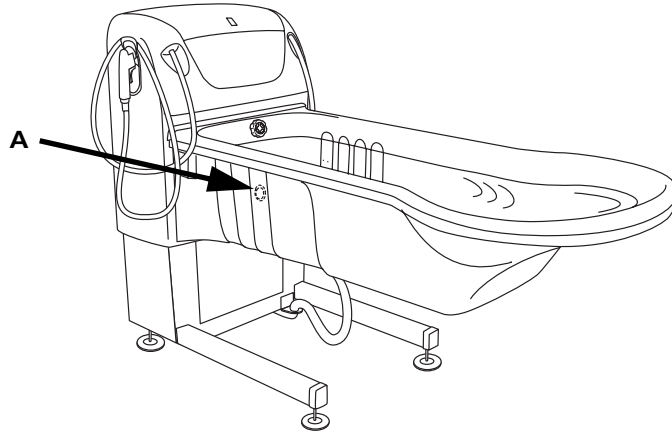

4

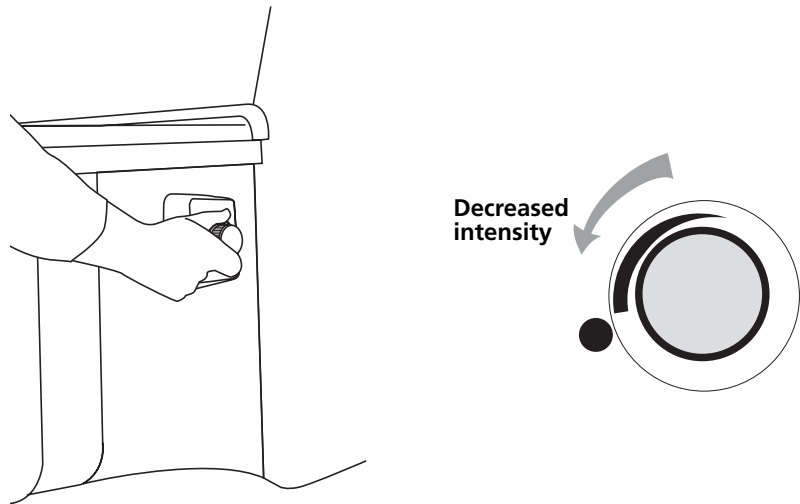

5

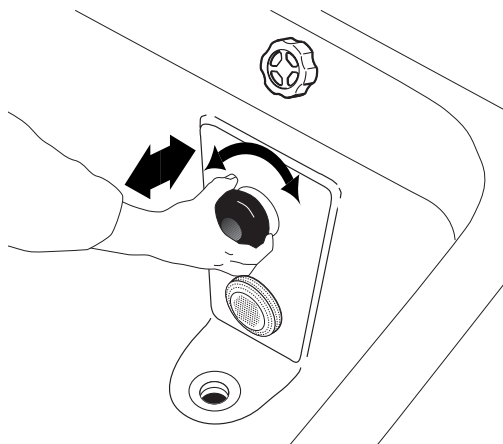

Treatment hose

- 1 If hydromassage is activated, stop by pressing the hydromassage button before the treatment hose is connected. Remove the hydromassage nozzle (Just pull it out).
- 2 Connect the treatment hose to the quick coupling in the bath tub.
(The treatment hose and the built-in jet within the tub cannot be used simultaneously).
- 3 Direct the treatment hose nozzle into the water. Make sure the air inlet (A) is above the water surface.
- 4 Hydromassage from the treatment hose starts when the hydromassage button on the control panel is pressed.
(After 15 minutes the treatment is automatically ended. During these 15 minutes, the treatment can be stopped by pressing the hydromassage button.)
- 5 To adjust the jet stream intensity:
Turn the outermost part of the treatment hose nozzle.
- 6 When the two dots on the nozzle is aligned, the jet stream is most intensive. When turning the nozzle 90°, the jet stream intensity decreases. When turning the nozzle 90° more, the jet stream intensity increases and so on (see figure).
- 7 When the local treatment is finished, press the hydromassage button on the control panel.
- 8 Remove the treatment hose from the quick coupling by pushing the hose while pulling the hose bracket.

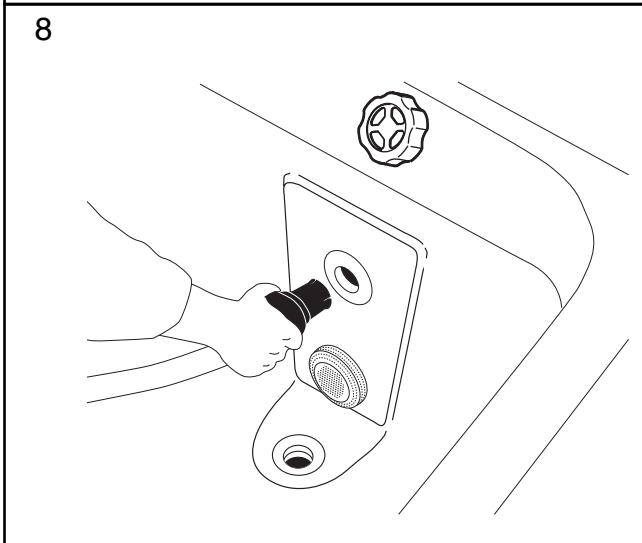
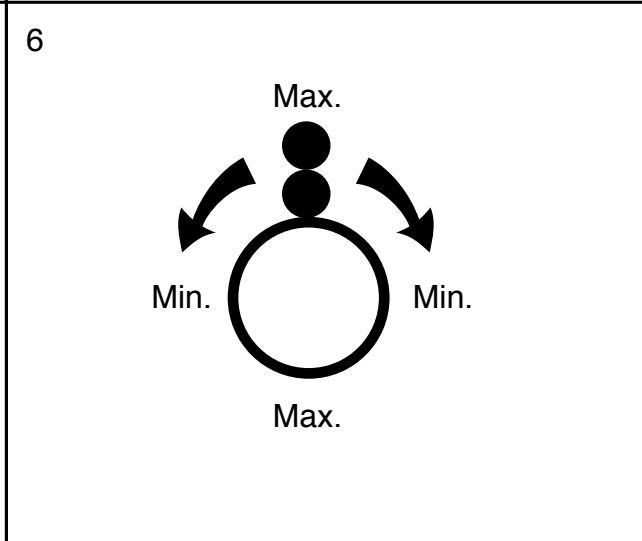
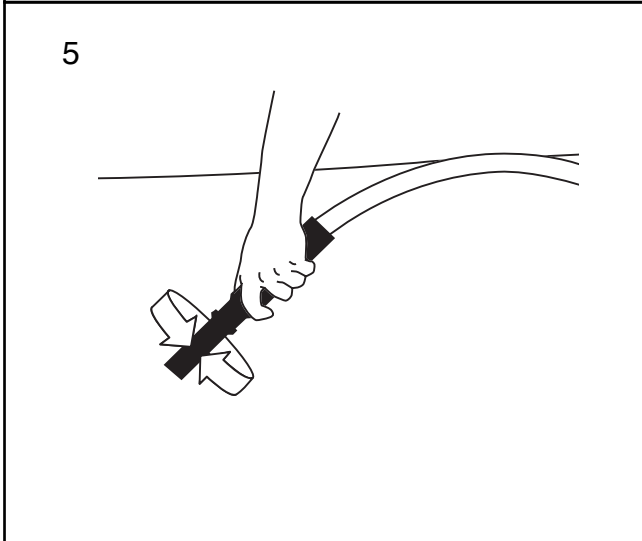
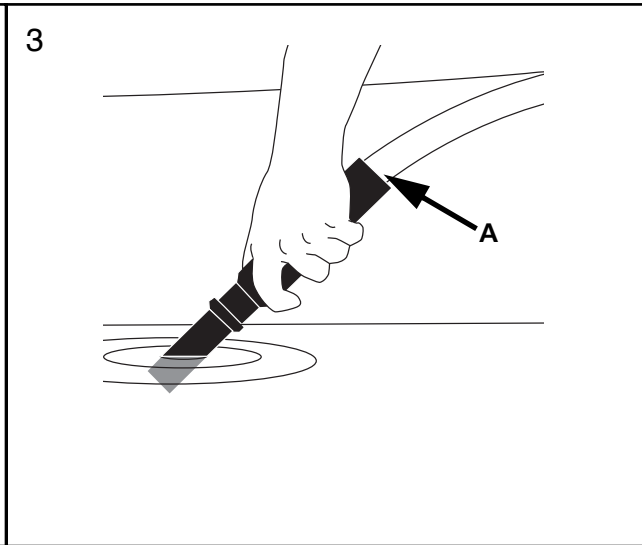
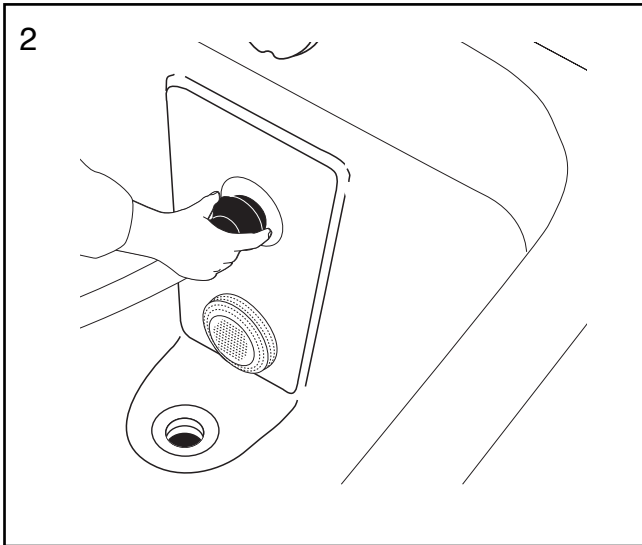

Hydrosound



WARNING!
Hydrosound should not be used by pregnant women.

Arjo Hydrosound is a method of cleaning patients by means of low frequency, low intensity ultra sound. Working together with water, it's the most effective and skin friendly method of cleaning the skin.

The amount of time and intensity setting used for Hydrosound cleaning is a matter of choice consistent with the degree of patient cleanliness required and patient comfort. The longer the time of exposure and the greater the intensity setting, the more efficient the cleaning will be.

For patients experiencing Hydrosound for the first time, it is recommended that the intensity is set at the lower levels before using the higher intensity settings.



WARNING!
Avoid continuous skin contact with the Hydrosound transducer plate (illustration 2 - A). Lack of cooling medium for a prolonged period of time may cause the surface temperature of the hydrosound transducer to rise.

Using the hydrosound system

Prepare the bath according to the section "Preparations for Bath".

- 1 Add Arjosound Water Conditioner after activating the filling process. Press the Arjosound dispenser button on the control panel.
Check that the conditioner mixes into the water.



WARNING!
Only use other bath oils and skin conditioners than Arjosound Water Conditioner together with the Hydrosound. Use of incompatible bath oils or additives can inhibit the ultrasound waves.

- 2 Check that the water level covers the top of the Hydrosound Transducing Plate (A).
- 3 Start hydrosound by pressing the hydrosound button on the control panel. After 15 minutes the treatment is automatically ended. During these 15 minutes, the treatment can be stopped by pressing the hydrosound button.
- 4 It is possible to select different intensity levels by turning the knob on the side of the bathtub. The intensity is increased by turning the knob clockwise. The levels 20, 40, 60, 80 or 100 mW/cm² will be chosen step by step. The diode lamp (B) will show a steady green light and a buzzing sound will be heard when any active level is chosen. A yellow light indicates a test-level. A yellow flashing light will be shown if a problem occurs during the treatment.
See figure.
- 5 Bathe the resident with hydrosound activated.



WARNING!
Do not place the residents head below the water surface or in the vicinity of the Hydrosound Transducing Plate.

- 6 Press the hydrosound button on the control panel to stop the hydrosound.
- 7 Raise the resident out of the water, and then rinse the resident thoroughly with the shower to remove loosened particles from the skin.

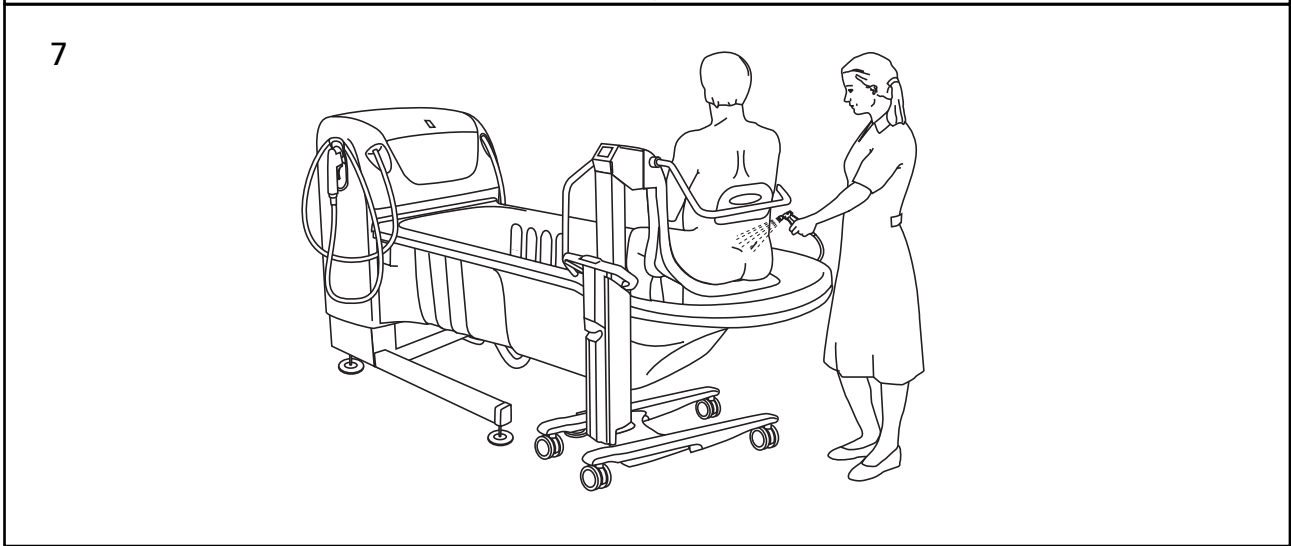
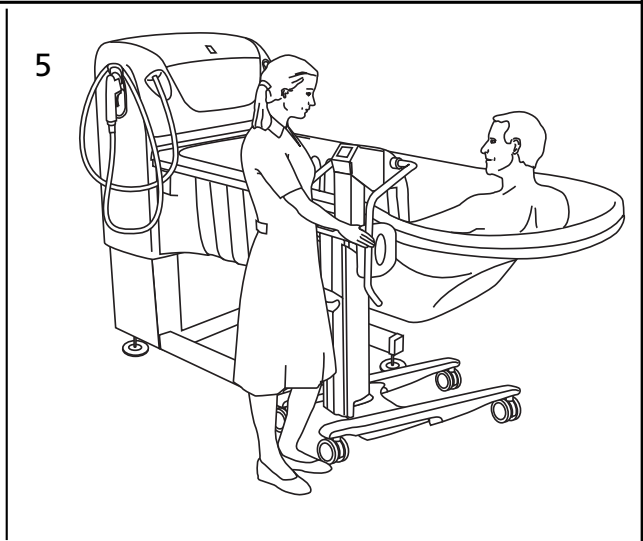
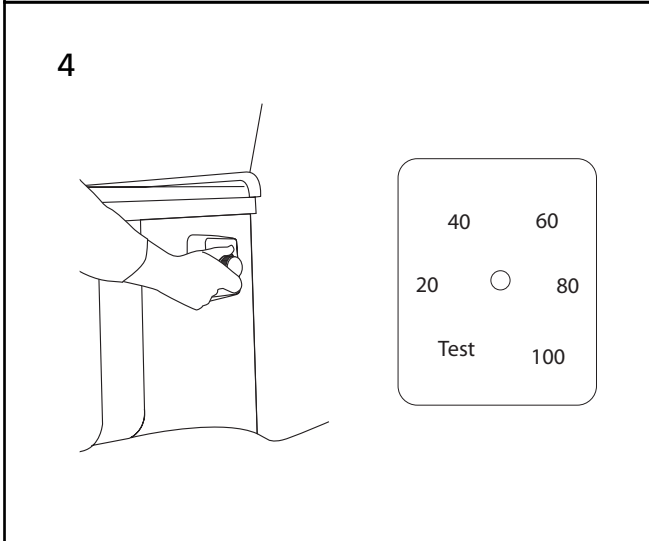
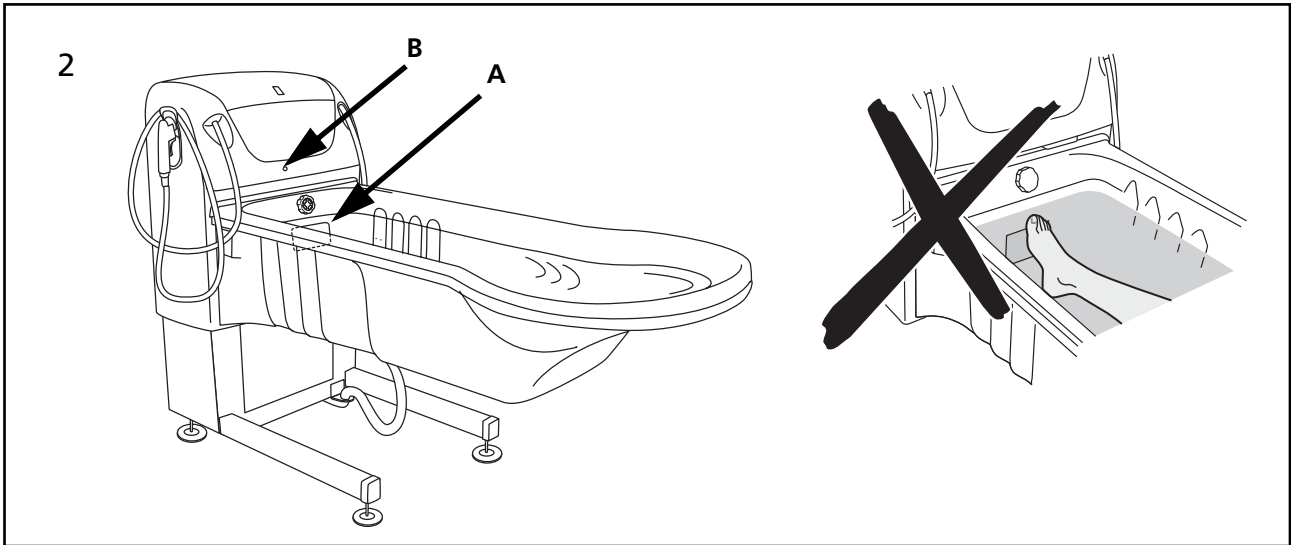

Disinfection/cleaning instructions

Arjo Clean

For optimal performance use Arjo Clean only.

For any questions regarding the proper disinfection procedure or for liquid product ordering information, call our liquid product consultants at the office listed on the back cover of this manual.

Disinfectant/cleaning spray

The spray handle is placed under the lid of the panel and has a trigger handle.



WARNING:

Always use protective gloves and protective eye wear when dealing with concentrated disinfectant. Avoid getting it on your skin or in your eyes. If contact occurs, rinse with copious amounts of water. If skin or eyes become irritated, consult a physician. Carefully follow the instructions on the Arjo Clean.

Preparations

- 1 Open the panel cover and place a bottle of Arjo Clean in the bottom of the recess and connect the bottle connection.
- 2 Lift the disinfectant shower handle and direct it against the bottom of the bath tub.
- 3 Press the disinfection button on the control panel.
- 4 Check the liquid value on the flowmeter so it is in accordance with the setting range in the recommendations.
- 5 If necessary, adjust the screw on the bottle.

If your bath system is equipped with hydromassage go to page 28.

1a

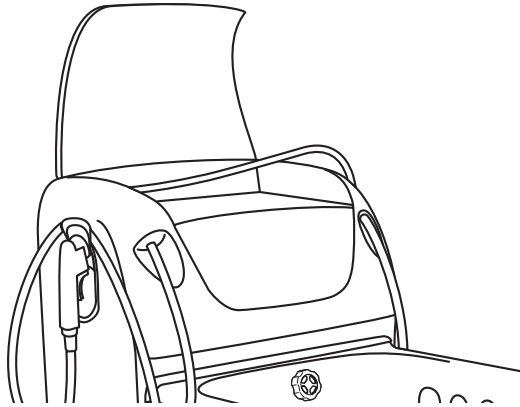

1b

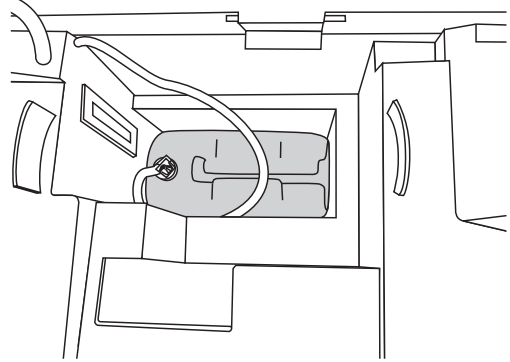

4

Mixture of cleaning agent

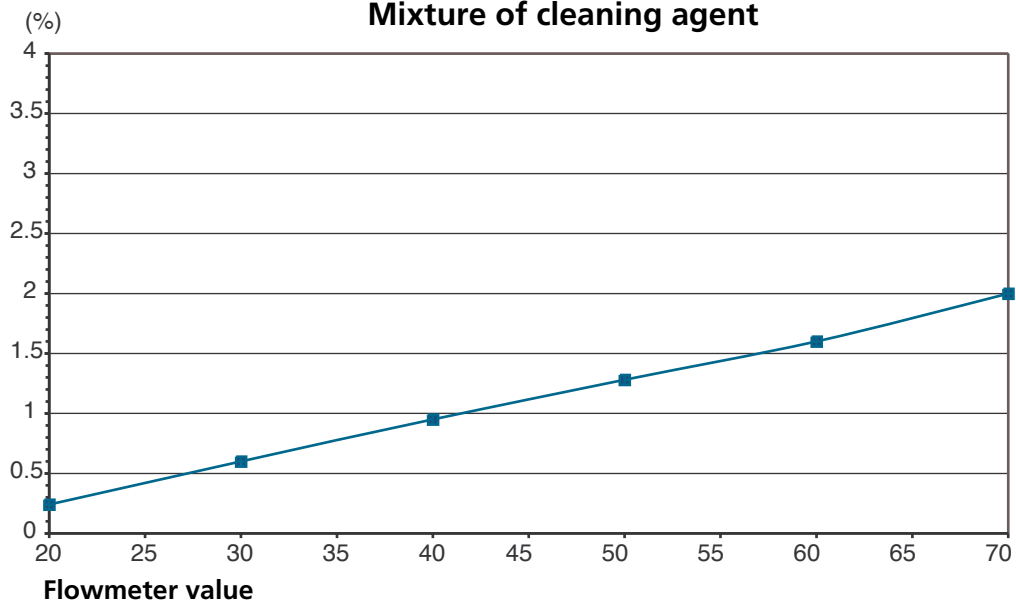

Flowmeter value

ArjoClean (1.6 % ≈ 60)

5

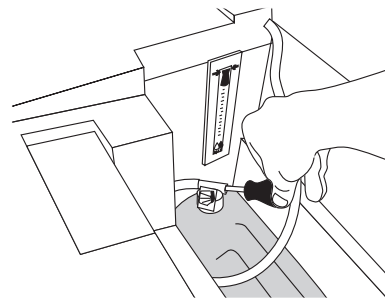

Stillbath and Hydrosound

Procedure to be performed before the first bath of the day and then after every resident.

NOTE!

Make sure that there is an appropriate mixture of disinfectant liquid to the water by means of checking the flow meter.

- 1 Raise the bath tub to convenient working height by pressing arrow up button on the control panel.
- 2 Insert the drainage plug.
- 3 Direct the disinfectant spray handle against the bottom of the bath tub.
- 4 Press the disinfectant button.
- 5 Spray all the bath tub, the foot rest, the pillow and lift with mattresses, if any, with the disinfectant sprayer.
- 6 Spray into the surface overflow outlet.
- 7 Press the disinfectant button and place the disinfectant spray handle under the lid.
- 8 Scrub the tub using the disinfectant at the bottom of the bath tub.
- 9 Let the Arjo Clean take effect according to the recommendation label on the bottle.
- 10 Remove the drainage plug.
- 11 Press the button for resident shower on the control panel and rinse bath tub and accessories carefully with the resident shower.
- 12 Press the button for resident shower on the control panel.
- 13 Let the pillow dry with the suction cups upwards at the bottom of the bath tub.

After the last cleaning/disinfection for the day:
Dry the bath tub and accessories with a clean towel.

NOTE!

Clean and dry the sensors on the inside of the tub with a soft cloth.

5

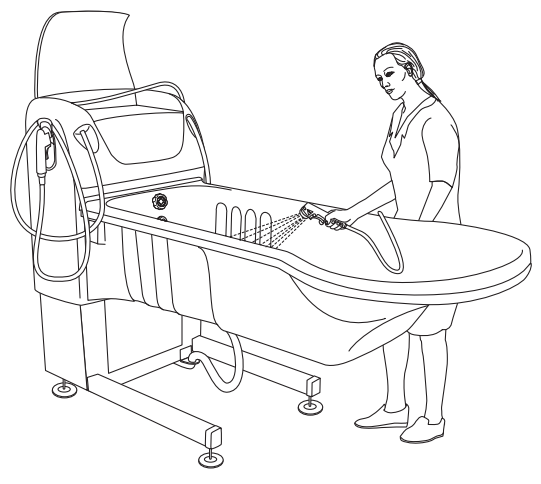

6

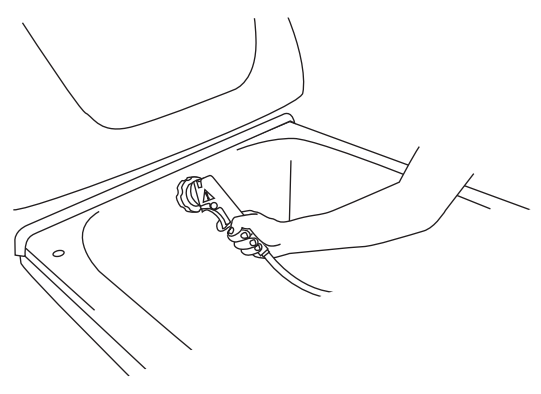

8

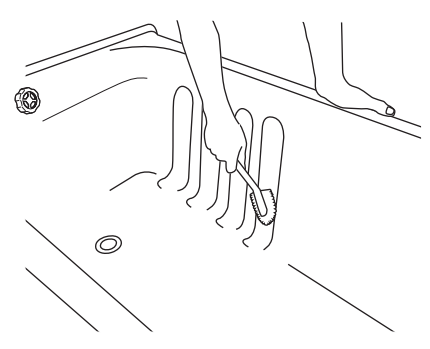

Hydromassage

Procedure to be performed before the first bath of the day and then after every resident.

The treatment hose is an accessory. If you don't have any treatment hose, just pass over the instructions given on how to use it.

Read through the following instructions carefully before starting!

NOTE!

Make sure that there is an appropriate mixture of disinfectant liquid to the water by means of checking the flow meter.

- 1 Raise the bath tub to convenient working height by pressing arrow up button on the control panel.
- 2 Close the drainage plug.
- 3 Remove inlet screen and clean it separately.
- 4 Remove the hydromassage nozzle (Just pull it out).
- 5 Insert the treatment hose in the hydromassage outlet. Make sure that the water flow is in the max position.
- 6 Connect the disinfection spray handle into the hydromassage inlet.
- 7 Press the disinfection button on the control panel and spray. Press the trigger handle until water comes out of the treatment hose/hydromassage outlet.
- 8 Remove the disinfectant spray handle and direct it against the bottom of the bath tub.
- 9 Spray all the bath tub, the foot rest, the pillow and lift with mattresses, if any, with the disinfectant sprayer.
- 10 Spray into the surface overflow outlet and into the holes where the filter and hydromassage nozzle were placed.
(When the treatment hose is used, spray the outside too.)
- 11 Press the disinfectant button and place the disinfectant spray handle under the lid
- 12 Scrub the tub using the disinfectant at the bottom of the bath tub.
- 13 Let the Arjo Clean take effect according to the recommendation label on the bottle.

- 14 Open the drainage plug.
- 15 Connect the resident shower handle into the hydromassage inlet.
- 16 Press the resident shower button on the control panel and spray until clean water comes out of the treatment hose/hydromassage outlet.
- 17 Remove the resident shower hose and direct it against the bottom of the bath tub.
- 18 Rinse bath tub and accessories carefully with the resident shower.
- 19 Remove the treatment hose from the quick coupling by pushing the hose while pulling the hose bracket.
- 20 Rinse into the hydromassage outlet.
- 21 Press the button for resident shower on the control panel.
- 22 Insert the cleaned filter and make sure that the area without holes is directed downwards
- 23 Let the pillow dry with the suction cups upwards at the bottom of the bath tub.

After the last cleaning/disinfection for the day:
Dry the bath tub and accessories.

NOTE!

Clean and dry the sensors on the inside of the tub with a soft cloth.

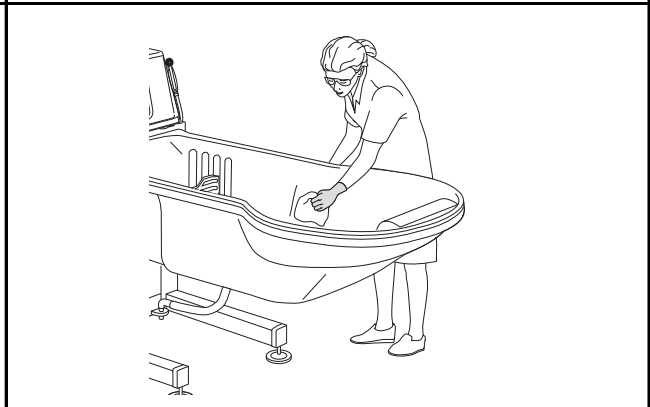
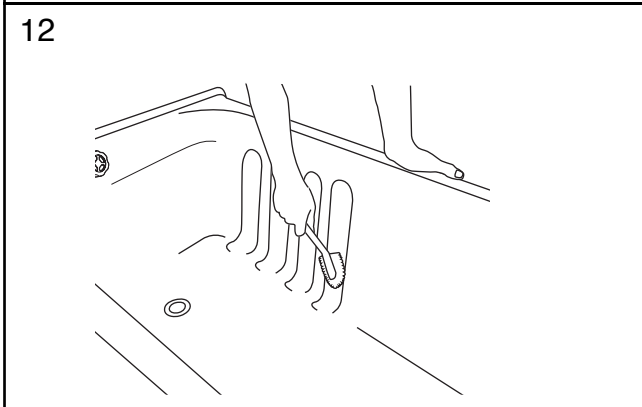
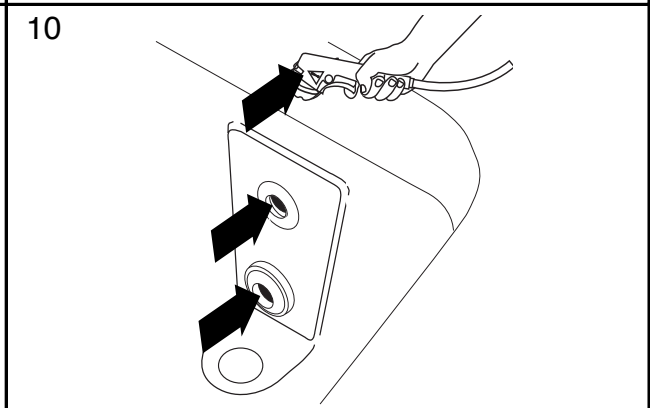
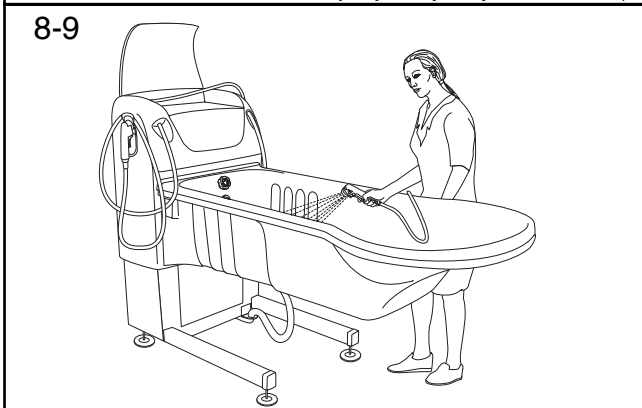
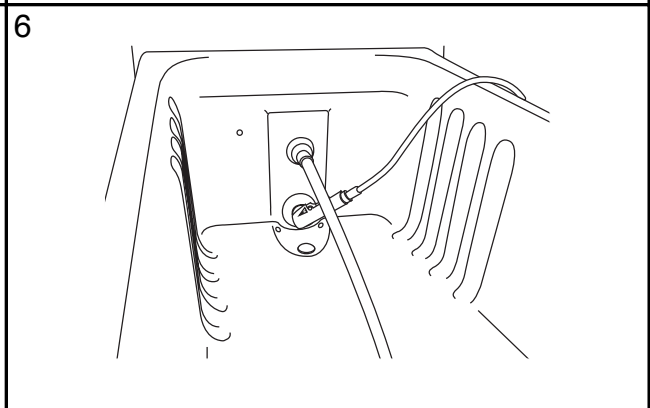
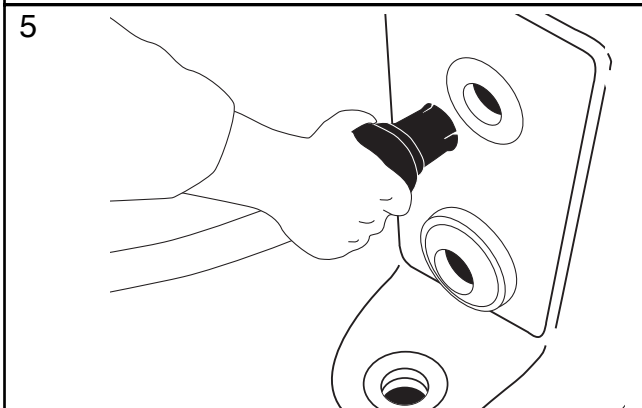
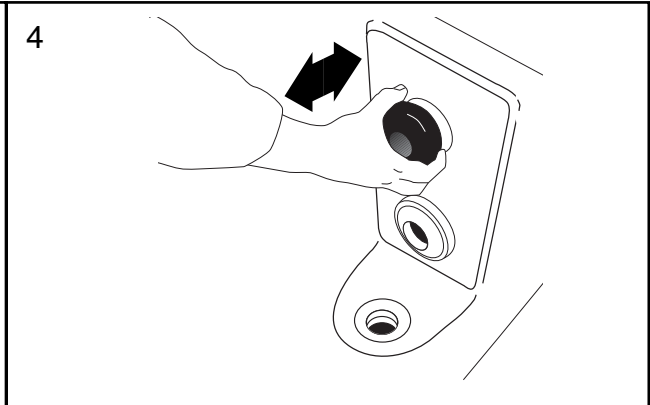
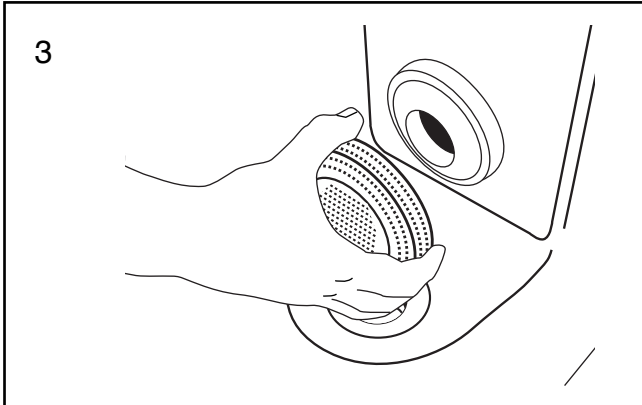

Stainless Steel

Instructions for cleaning of Ferro, the bath tub of stainless steel.

Removing of fingerprints, grease, soap etc.

Use ordinary cleaning-agents and white scotchbrite or a soft brush.

CAUTION

Never use green or brown scotchbrite nor steel wool.

- 1 Rinse with plenty of fresh water.
- 2 Dry with a clean rag to avoid water marks.
- 3 Aftertreat with *stainless steel polish* to get a preventive coating against fingerprints and water marks.

Removing of lime deposit (watermarks), mini corrosion and discoloration

- 1 Cover the area with stainless steel cleaner and let it work 10-20 minutes.



WARNING:

Use gloves and protective goggles to protect eyes and skin.

The agent can also attack plastics, wood, cloth etc.

Never use ordinary lime remover, because it usually contains hydrochloric acid and that will destroy the stainless steel.

- 2 Rinse with plenty of fresh water.
- 3 Dry with a clean rag to avoid water marks.
- 4 Aftertreat with *stainless steel polish* to get a preventive coating against fingerprints and water marks.

General information/cleaning

We strongly recommend that you follow the Disinfection/Cleaning instructions when disinfecting the tub.

If you are not sure of the effect on the bath when using certain agents/fluids, please contact your nearest Arjo office for further information.

- **When using bath water additives**, ensure that the additives are fully dissolved in water before adding to the prefilled bath tub. After bathing with bath additives the tub must be carefully rinsed with clean water.
- For daily disinfection we recommend ArjoClean, especially developed for use with Arjo Bath Systems, in order to avoid scratches in the plastic surface.
- In the dispenser system it is recommended to use only: ArjoCare, ArjoOil or if hydrosound: ArjoSound.

CAUTION

Do not use the following substances in the bath: Iodine, bromide, methylene blue, potassium permanganate etc. (discoloration) chlorine, hydrogen peroxides or other oxidizing agents, heavy-metal chlorides, petroleum based solvents, trichlorethylene, citric acid, phenol based disinfectants or similar solvents (damages the plastic surfaces).

PVC-coated cloth mattresses and pillows

- After each resident's use, mattresses and pillows should be cleaned with Arjo Disinfectant/cleaner, or a soap or synthetic detergent and water, at a temperature of maximum room temperature.
- Use a cloth. Rinse carefully with clean water. If the water is hard, wipe mattresses/pillows with a slightly damp cloth to help prevent lime stains. Allow to dry naturally.

If a hot air drier is used, the temperature must not exceed 80 °C (175 °F).

Care and maintenance

The equipment is subject to wear and tear, and the following maintenance instructions must be performed when specified to ensure that the equipment remains within its original manufacturing specification. Care and Maintenance shall be carried out in accordance with the Preventive Maintenance Schedule below.



Safety related maintenance must be carried out by qualified personnel, fully trained in servicing by ARJO, using correct tools and knowledge of procedures. Failure to meet these requirements could result in personal injuries and/or unsafe equipment.

Preventive Maintenance Schedule -Rhapsody/Primo P200

Action/check	Every DAY	Every WEEK	Every MONT H	Every YEAR	Every 3:rd YEAR	Every 5:th YEAR
Customer obligation						
Cleaning/Disinfection	X					
Check the liquid levels	X					
Visually check all exposed parts		X				
Check pillow		X				
Visually check hoses, pipes and connections		X				
Perform functionality test		X				
Check/ clean shower heads			X			
Check/clean filters, incoming water			X			
Exercise the thermostat mixer			X			
Authorized Service						
Lubricate moving parts				X		
Check/replace seal kit or complete shower handle				X		
Check oil level				X		
Check all vital parts for corrosion and damage				X		
Perform full feature functionality test				X		
Check mechanical attachments				X		
Check that the latest updates have been implemented				X		
Check function of emergency lowering				X		
Check/adjust thermostatic mixer incl. seal kit/complete thermostatic unit				X		
Check/replace flow restrictors				X		
Check valves and membranes, replace if necessary				X		
Check dosage disinfection				X		
Check hoses and connections for leaks and damage				X		
Check the earth wiring connection				X		
Check/clean filters, incoming water				X		
Replace batteries					X	
Replace all pressurized water hoses						X

Customer obligations shall be carried out by qualified personnel following the instructions in this manual.

Trouble shooting

If the product does not work as intended, immediately contact your local ARJO representative for support.

Every day

- **Cleaning/disinfection.**
Rhapsody/Primo has to be cleaned immediately after use. ARJO cleaning agents and liquid treatment should be used in **recommended concentrations**. See further disinfecting/cleaning instructions on page 24-31.
- **Check the liquid level** in the bottles of Arjo-Clean, ArjoCare and ArjoOil or if hydrosound: ArjoSound.

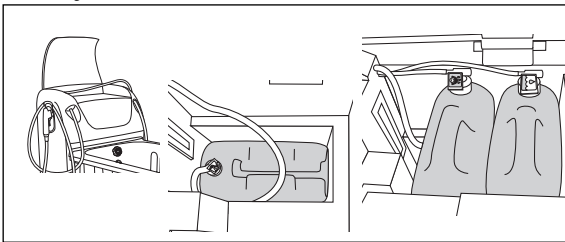

Every week

- **Visually check all exposed parts**, especially where personal contact is made by either the resident or caregiver. Make sure no cracks or sharp edges have developed that could cause the resident or user injury or that has become unhygienic.
- **Check pillow (1)** to make sure there are no cracks or tears that would allow water to get into the filling. If there is such damage, replace the pillow.

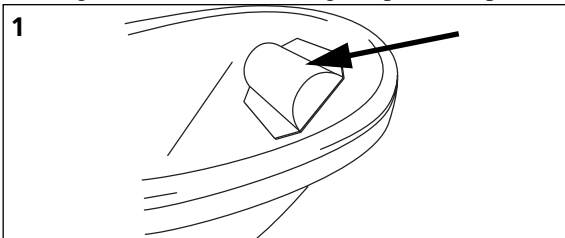

- **Visually check hoses, pipes and connections (2).** Visually inspect for leaks of any kind by looking under tub, lid and behind the panel.

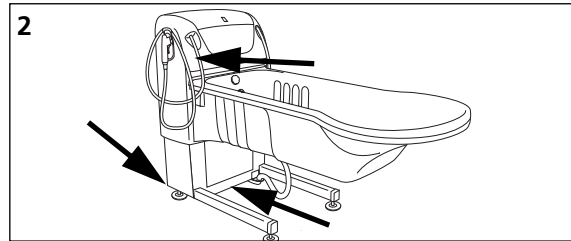

- **Perform functionality test (3).** Test all panel and disinfection functions. With water on: check shower hose and shower handle for damage.

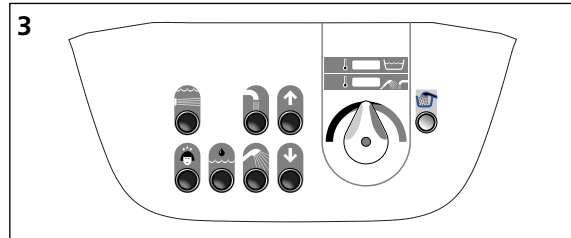

Every month

- **Remove and clean the strainers in the shower heads (4).**
 - 1 Loosen the screw.
 - 2 Remove the parts according to the illustration below.
 - 3 Clean carefully.
 - 4 Re-assemble. The parts (a) must be assembled before they will be set into the handle.

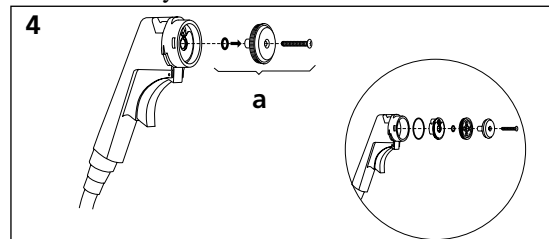

- 5 Tighten the screw carefully.

- **Check/clean filters, incoming water (5)** .A rinsing valve with a filter is mounted on each of the two water supply hoses found in the back of the panel. The filter in both valves should be rinsed as follows:

- 1 Close the valves (a). The handles (red for hot water and blue for cold) should be in a cross position.



WARNING:
Make sure that the valve is closed before removing the cap - especially important for the hot water valve.

- 2 Remove the cap (b) with a wrench.
- 3 Pull out the filter (c) and clean it carefully in water.
- 4 Reassemble.
- 5 Open the valves.

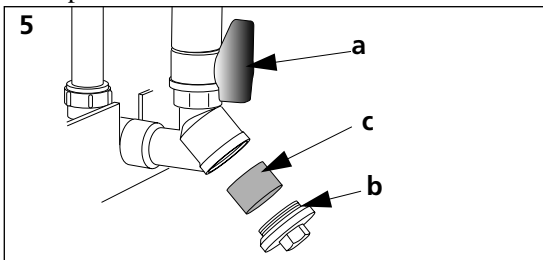

Exercise the thermostat mixer (6)

- Turn the temperature control back and forth over the whole temperature range with water on. This is particularly important in areas with hard water.

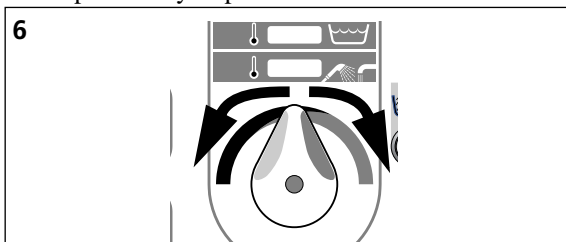

Yearly

Rhapsody/Primo has to be serviced according to the Preventive Maintenance Schedule (ARJO Authorized Service).

For GB models only

The system is approved to NHS Model Engineering Specifications D 08 Thermostatic Mixing Valves (Health Care Premises)TMW 3. The system requires regular test and maintenance by ARJO trained personnel according to the enclosed document 10.AR.02/GB. Failure in meeting this requirement may jeopardise the valve performing to TMV 3 specifications.

Technical specifications

Electric supply

See accompanying document *Assembling and Installations Instructions*.



WARNING!

The unit must be connected from the bonding point labeled on the unit to the equipotential bonding point of the room.

The unit must be continuously powered and connected to a mains disconnection device and to separate fuse with ground fault interrupter in accordance with local codes and regulations.

Water supply

See accompanying document *Assembling and Installations Instructions*.

Water drainage

See accompanying document *Assembling and Installations Instructions*.

Floor loads

See accompanying document *Assembling and Installations Instructions*.



WARNING!

Foot pads must be bolted to the floor when rigid pipe connections are used.

Safe Working Load

The maximum total weight of resident + water: 500 kg (1100 lb)

Operating conditions

Max ambient temperature	40 °C (104 °F)
Max relative humidity	80 % not condensed at 20 °C (68 °F)
Atmospheric pressure range	500 hPa to 1060 hPa

Transport and Storage

Ambient temperature range	30°C- (22°F) to 70°C (158°F)
Relative humidity range	80 % not condensed at 20 °C (68 °F)
Atmospheric pressure range	500 hPa to 1060 hPa

Recycling

Package	Wood and corrugated cardboard, recyclable
The product	Electric, steel and plastic parts shall be separated and recycled according to marking on the unit

Accessories

Calypso

The Calypso is a vertically adjustable lift hygiene chair and is specially adapted to Arjo bath and shower systems.

Using the Calypso you can transfer an active resident from bed to bath and back again, without effort or undue movement.

Alenti

In addition to the same functions as the Calypso has, the Alenti is also equipped with central braking.

The seat in one piece of polyurethane assures patient comfort as well as quick disinfection.

Bolero

The Bolero is a vertically adjustable lift bath trolley and is specially adapted to Arjo bath and shower systems.

Using the Bolero, a recumbent resident can be lifted effortlessly from a bed, bathed and taken back to bed without disturbance.

Miranti

Miranti is a unique, powered Lift Bath Trolley. Thanks to the power drive of the Miranti, the caregiver can drive the trolley without effort. The powered backrest facilitates transfer from bed. The stretcher of polyurethane assures patient comfort as well as quick disinfection.

ArjoClean

ArjoCare

ArjoOil

If Hydrosound: ArjoSound

Tray (for bath utensils) ARA0007-01

Alenti

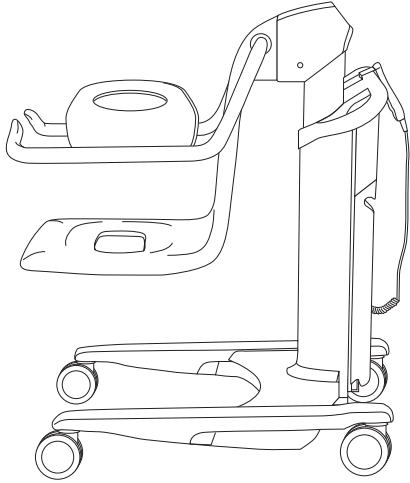

Calypso

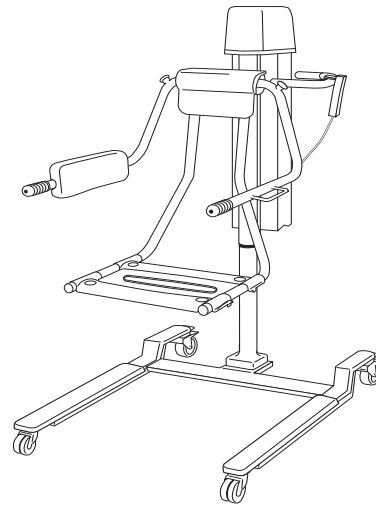

Miranti



Bolero



ArjoClean, ArjoCare, ArjoOil, (ArjoSound)

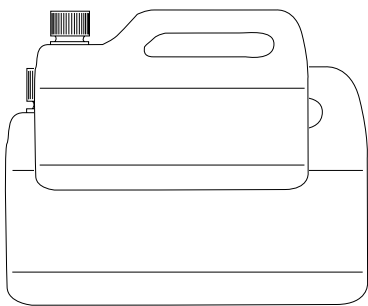

Tray

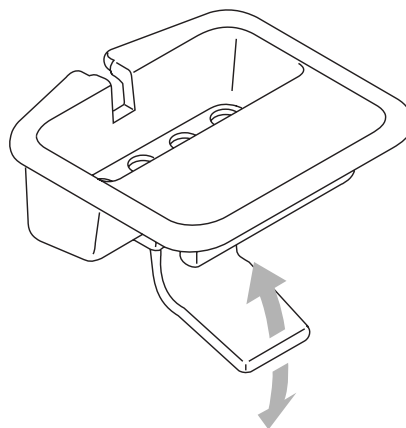

AUSTRALIA

ARJO Hospital Equipment Pty Ltd
154 Lytton Road
BULIMBA
Brisbane QLD 4171
Australien
Tel: 07-3395 6311
Fax: 07-3395 6712

AUSTRIA

ARJO-Sic GmbH
Föhrenweg 5
A-6065 THAUR
Tel: 05223-49 33 50
Fax: 05223-49 33 50 - 75

BELGIUM

ARJO Hospital Equipment nv-sa
Ternesseelei 248
B-2160 WOMMELGEM
Tel: 03 353 91 00
Fax: 03 353 91 01
E-mail: info@arjo.be

CANADA

ARJO Canada Inc.
1575 South Gateway Road
Unit "C"
MISSISSAUGA, ON, L4W 5J1
Tel: 1-800-665-4831
Fax: 1-800-309-1116
E-mail: info@arjo.ca
Web page: www.arjo.com.

CZECH REPUBLIC

ARJO Hospital Equipment s.r.o.
Hlinky 118
CZ- 603 00 BRNO
Tel.: 549 254 252
Fax: 541 213 550

DENMARK

ARJO Scandinavia
Postboks 51
DK-4632 BJAEVERSKOV
Tel: 45 93 27 37
Fax: 45 93 27 39

FAR EAST

ARJO Far East Limited
Unit 3A, 4/F., block B Hoi Luen Industrial Centre
55 Hoi Yuen Road, Kwun Tong, Kowloon
HONG KONG
Tel: 2508 9553
Fax: 2508 1416

FINLAND

OY Vestek AB
Martinkuja 4
FI-02270 ESPOO
Tel: 9 8870120
Fax: 9 88701291

FRANCE

ARJO Equipements Hospitaliers S.A.
45, Avenue de l'Europe
Eurocit BP 133
F-59436 RONCQ CEDEX
Tel: 03 20 28 13 13
Fax: 03 20 28 13 14
E-mail: info@arjo.fr

GERMANY

ARJO GmbH
Christof - Ruthof - Weg 6
D-55252 MAINZ-KASTEL
Tel: 06134-186-0
Fax: 06134 186 160
E-mail: info@arjo.de

GREECE

C. Psimitis Co Ltd
Dimitriou Andr. 59
GR-16121 KAISARIANI ATTIKIS
Tel: 21 0724 36 68
Fax: 21 0721 55 53

ITALY

ARJO Italia S.p.A.
Via Tor Vergata 432
I-00133 ROMA
Tel: 06-87426211
Fax: 06-87426222
E-mail: promo@arjo.it

THE NETHERLANDS

ARJO Nederland BV
De Blomboogerd 8
4003 BX TIEL
Postbus 6116
NL-4000 HC TIEL
Tel: 0344-64 08 00
Fax: 0344-64 08 85
E-mail: info@arjo.nl

NORWAY

ARJO Scandinavia
Ryenstubben 2
N-0679 OSLO
Tel: 98 28 11 70
Fax: 22 57 06 52

POLAND

ARJO Poland Sp.z o.o.
Ul. Lirowa 27
PL-02-387 WARSZAWA
Tel: 22 882 06 26
Fax: 22 882 06 29

PORTUGAL

ARJO International AB
Rua das Valas 82
PT 4510-154 JOVIM GONDOMAR
Tel: 22 450 32 48
Fax: 22 450 03 27

SPAIN

ARJO Spain, S.A
C/ San Rafael, No. 6
E-28108 ALCOBENDAS
Tel: 902 300 126
Fax: 902 300 191
E-mail: arjospain@arjospain.es

SWEDEN

ARJO Scandinavia AB
Verkstadsvägen 5
Box 61
SE-241 21 ESLÖV
Tel: 0413-645 00
Fax: 0413-645 83
E-mail: kundservice@arjo.se

SWITZERLAND

ARJO-Sic AG
Florenzstr. 1d
Postfach
CH-4023 BASEL
Tel: 061-337 97 77
Fax: 061-311 97 42

UNITED KINGDOM

ARJO Med AB Limited
St Catherine Street
GLOUCESTER GL1 2SL
Tel: 08702 430 430
Fax: 01452-525 207

USA

ARJO Inc.
50 North Gary Avenue
ROSELLE, IL 60172
Tel: 1-800-323-1245
Fax: 1-888-594-2756



FM 24321 ISO 9001
MD 87841 ISO 13485



153210

ARJO ...with people in mind.

www.arjo.com

info@arjo.com

MEMBER OF THE GETINGE GROUP

If your country is not listed here, please contact your local distributor
or: ARJO INTERNATIONAL AB, Box 61, S-241 21 ESLÖV, SWEDEN
Tel: +46 413 645 00; Fax: +46 413 645 63;
www.arjo.com